

Product Specification

9.95 Gbps ~ 11.3Gbps 0°C ~ 85°C 20km SFP+

CLSFP1310GLR20I-LF

Product Features

- 9.95 Gbps ~ 11.3Gbps data links
- 20km with 9/125μm SMF
- 1310nm DFB laser
- Duplex LC Connector
- Hot-pluggable SFP+ footprint
- Single 3.3V power supply
- Operating temperature: 0°C to 85°C
- RoHS
- Power Consumption < 1.5W
- Digital Diagnostic Monitor (DDM) meet SFF-8472

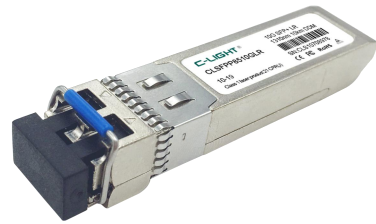

Applications

- √ 10GBase-LR/LW 10G Ethernet
- √ CPRI 10G

1. Product Description

The CLSFP1310GLR20I-LF is a 9.95 Gbps ~ 11.3Gbps enhanced small form factor pluggable SFP+ transceiver compatible with 10GBASE-LR/LW and 10G Fiber Channel 1200-SM-LL-L. It is suitable for high temperature single-mode fiber (SMF) communications in 10Gbps Ethernet and 10G Fiber Channel.

2. Regulatory Compliance

C-light transceivers are Class 1 Laser Products comply with FDA regulations. Meet Class 1 eye safety requirements of EN 60825 and the electrical safety requirements of EN 60950. Meet RoHS, EN55022 class B, IEC 61000-4-2.

3. Absolute Maximum Ratings

Parameter	Symbol	Min.	Max.	Unit
Supply Voltage	V _{CC}	-0.5	4	V
Storage Temperature	T _s	-40	85	°C
Operating Case Temperature	T _c	0	85	°C

4. Recommended Operating Conditions

Parameter	Symbol	Min.	Typical	Max.	Unit
Operating Case Temperature	T _c	0		85	°C
Power Supply Voltage	V _{CC}	3.135	3.3	3.465	V
Power Supply Current	I _{CC}			430	mA
Data Rate		9.95	10	11.3	Gbps
Max Link Length on 9/125μm SMF	L _{max}		20		km

5. Optical Characteristics

Parameter	Symbol	Min.	Typical	Max.	Unit
Transmitter					
Centre Wavelength	λ _c	1290	1310	1330	nm
Spectral Width (-20dB)	σ			1	nm
Average Output Power	P _{out}	-8.2		0.5	dBm
Extinction Ratio	ER	3.5			dB
Average Launch Power of Off Transmitter	P _{off}			-30	dBm
Receiver					
Centre Wavelength	λ _c	1260	1310	1355	nm
Receiver Sensitivity	P _{IN}			-18	dBm
Receiver Overload	P _{max}	2			dBm
LOS De-Assert	LOS _D			-20	dBm
LOS Assert	LOS _A	-30			dBm
LOS Hysteresis		0.5		4.5	dB

6. Electrical Characteristics

Parameter	Symbol	Min.	Typical	Max.	Unit
Transmitter					
Input Differential Impedance	Zin	90	100	110	Ω
Single ended data input swing	Vin	180		700	mV
Tx-Dis Disable	Vd	2.0		Vcc	V
Tx-Dis Enable	Ven	0		0.8	V
Receiver					
Single ended data output swing	Vout	300		850	mV
Rx-Los Fault	Vlf	2.0		Vcchost	V
Rx-Los Normal	Vln	0		0+0.8	V
Output rise and fall time	Tr, Tf	30			ps

7. Pin Descriptions

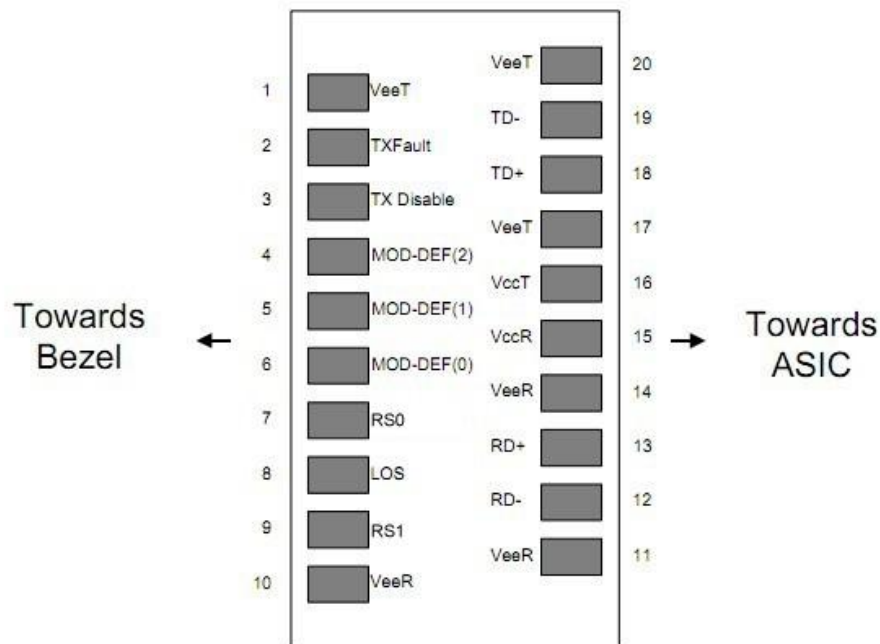

Diagram of Host Board Connector Block Pin Numbers and Names

Pin	Symbol	Description	Ref.
1	VEET	Transmitter Ground (Common with Receiver Ground)	7.1
2	TFAULT	Transmitter Fault.	
3	TDIS	Transmitter Disable. Laser output disabled on high or open.	7.2
4	MOD_DEF(2)	Module Definition 2. Data line for Serial ID.	7.3
5	MOD_DEF(1)	Module Definition 1. Clock line for Serial ID.	7.3
6	MOD_DEF(0)	Module Definition 0. Grounded within the module.	7.3
7	RS0	Rate Select0, optionally controls SFP+ module receiver. When high input signaling rate > 4.25 GBd and when low input signaling rate < 4.25 GBd	
8	LOS	Loss of Signal indication. Logic 0 indicates normal operation.	7.4
9	RS1	Rate Select1, optionally controls SFP+ module receiver. When high input signaling rate > 4.25 GBd and when low input signaling rate < 4.25 GBd	
10	VEER	Receiver Ground (Common with Transmitter Ground)	7.1
11	VEER	Receiver Ground (Common with Transmitter Ground)	7.1
12	RD-	Receiver Inverted DATA out. AC Coupled.	
13	RD+	Receiver Non-inverted DATA out. AC Coupled.	
14	VEER	Receiver Ground (Common with Transmitter Ground)	7.1
15	VCCR	Receiver Power Supply	
16	VCCT	Transmitter Power Supply	
17	VEET	Transmitter Ground (Common with Receiver Ground)	7.1
18	TD+	Transmitter Non-Inverted DATA in. AC Coupled.	
19	TD-	Transmitter Inverted DATA in. AC Coupled.	
20	VEET	Transmitter Ground (Common with Receiver Ground)	7.1

Notes:

7.1 Circuit ground is internally isolated from chassis ground.

7.2 Laser output disabled on TDIS > 2.0V or open, enabled on TDIS < 0.8V.

7.3 Should be pulled up with 4.7k - 10kohms on host board to a voltage between 2.0V and 3.6V. MOD_DEF(0) pulls line low to indicate module is plugged in.

7.4 LOS is open collector output. Should be pulled up with 4.7k - 10kohms on host board to a voltage between 2.0V and 3.6V. Logic 0 indicates normal operation; logic 1 indicates loss of signal.

8. EEPROM

The 2-wire management interface according to SFF-8472 DDM (DOM) allows the device to read the status of the optical module (at least the parameters Tx, Rx, temperature, bias, voltage).

2 wire address 1010000X (A0h)

0~95
Serial ID Defined by SFP MSA (96 bytes)
96~127
Vendor Specific (32 bytes)
128~255
Reserved (128 bytes)

9. Mechanical Specifications

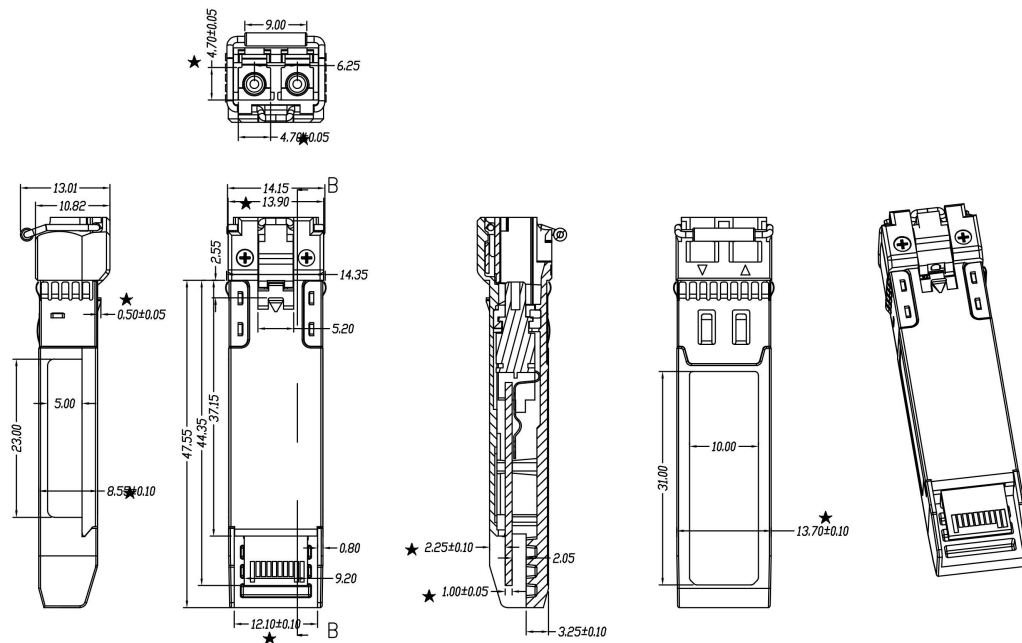

Ordering Information

Part No.	Data Rate	DDM	Wave	Fiber Type	Dist.	Temp.	Optical Interface
CLSFP1310GLR20I-LF	9.95~11.3 Gbps	yes	1310nm	SMF	20km	0~85°C	LC

CONTACT:

Shenzhen C-Light network communication co., Ltd

4F East, Building 1, Shunheda Factory Plant, Liuxiandong industrial park,
Xili, Nanshan Dist, Shenzhen PR. China

Tel: 86-755-2778-9180 **Fax:** 86-755-2778-9174

E-mail: sales@c-light.com <http://www.c-light.com>