

Product Specification

10Gbps 80KM SFP+ Transceiver

CLSFPP1510GZR

V20160818

Product Features

- Up to 10Gbps data links
- 80km with 9/125μm SMF
- 1550nm EML laser
- **APD receiver**
- Duplex LC Connector
- Hot-pluggable SFP+ footprint
- Single 3.3V power supply
- Operating temperature: 0°C to 70°C
- RoHS
- Digital Diagnostic Monitor(DDM)
- Power Consumption < 1.5W



Applications

√ 10GBase-ZR/ZW 10G Ethernet

1. Absolute Maximum Ratings

Parameter	Symbol	Min.	Max.	Unit
Supply Voltage	Vcc	-0.5	4	V
Storage Temperature	Ts	-40	85	°C
Operating Case Temperature	Tc	0	70	°C
Power Received Max	Pmax		-7	dBm

2. Recommended Operating Conditions

Parameter	Symbol	Min.	Typical	Max.	Unit
Operating Case Temperature	T _c	0		70	°C
Power Supply Voltage	V _{CC}	3.15	3.3	3.45	V
Power Supply Current	I _{CC}			450	mA
Data Rate			10		GBps
Max Link Length on 9/125μm SMF	L _{max}			80	km

3. Optical Characteristics

Parameter	Symbol	Min.	Typical	Max.	Unit
Transmitter					
Centre Wavelength	λ _c	1530	1550	1570	nm
Spectral Width (-20dB)	σ			1	nm
Average Output Power	P _{out}	0		5	dBm
Extinction Ratio	ER	8.2			dB
Average Launch Power of Off Transmitter	P _{off}			-30	dBm
Receiver					
Centre Wavelength	λ _c	1200	1550	1600	nm
Receiver Sensitivity	P _{IN}			-25	dBm
Receiver Overload	P _{max}	-7			dBm
LOS De-Assert	LOS _D			-35	dBm
LOS Assert	LOS _A	-37			dBm
LOS Hysteresis		0.5		4.5	dB

4. Electrical Characteristics

Parameter	Symbol	Min.	Typical	Max.	Unit
Transmitter					
Input Differential Impedance	Z _{in}	90	100	110	Ω
Data Input Swing Differential	V _{in}	250		1200	mV
Tx-Dis Disable	V _d	2.0		V _{CC}	V
Tx-Dis Enable	V _{en}	0		0.8	V

Receiver					
Data Output Swing Differential	Vout	250		800	mV
Rx-Los Fault	Vlf	2.0		VccHOST	V
Rx-Los Normal	Vln	0		0+0.8	V
Output rise and fall time	Tr, Tf	30			ps

5. Pin Descriptions

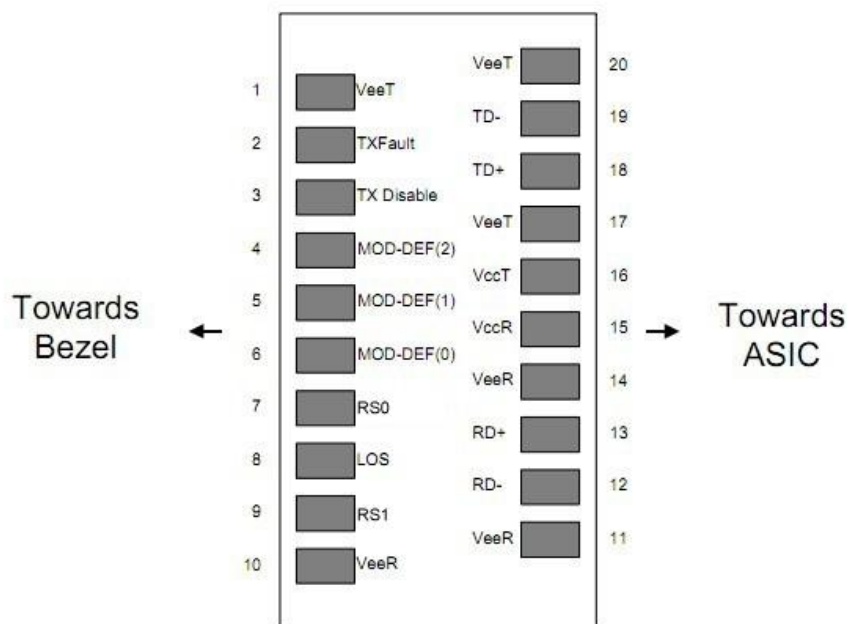

Diagram of Host Board Connector Block Pin Numbers and Names

Pin	Symbol	Description	Ref.
1	VEET	Transmitter Ground (Common with Receiver Ground)	7.1
2	TFAULT	Transmitter Fault. Not supported.	
3	TDIS	Transmitter Disable. Laser output disabled on high or open.	7.2
4	MOD_DEF(2)	Module Definition 2. Data line for Serial ID.	7.3
5	MOD_DEF(1)	Module Definition 1. Clock line for Serial ID.	7.3
6	MOD_DEF(0)	Module Definition 0. Grounded within the module.	7.3
7	RS0	Rate Select0, optionally controls SFP+ module receiver.	

		When high input signaling rate>4.25 GBd and when low input signaling rate<4.25GBd	
8	LOS	Loss of Signal indication. Logic 0 indicates normal operation.	7.4
9	RS1	Rate Select1, optionally controls SFP+ module receiver. When high input signaling rate>4.25 GBd and when low input signaling rate<4.25GBd	
10	VEER	Receiver Ground (Common with Transmitter Ground)	7.1
11	VEER	Receiver Ground (Common with Transmitter Ground)	7.1
12	RD-	Receiver Inverted DATA out. AC Coupled.	
13	RD+	Receiver Non-inverted DATA out. AC Coupled.	
14	VEER	Receiver Ground (Common with Transmitter Ground)	7.1
15	VCCR	Receiver Power Supply	
16	VCCT	Transmitter Power Supply	
17	VEET	Transmitter Ground (Common with Receiver Ground)	7.1
18	TD+	Transmitter Non-Inverted DATA in. AC Coupled.	
19	TD-	Transmitter Inverted DATA in. AC Coupled.	
20	VEET	Transmitter Ground (Common with Receiver Ground)	7.1

Notes:

5.1 Circuit ground is internally isolated from chassis ground.

5.2 Laser output disabled on TDIS >2.0V or open, enabled on TDIS <0.8V.

5.3 Should be pulled up with 4.7k - 10kohms on host board to a voltage between 2.0V and 3.6V. MOD_DEF(0) pulls line low to indicate module is plugged in.

5.4 LOS is open collector output. Should be pulled up with 4.7k -10kohms on host board to a voltage between 2.0V and 3.6V. Logic 0 indicates normal operation; logic 1 indicates loss of signal.

6. EEPROM & DDM THRESHOLD

6.1 EEPROM

2 wire address 1010000X (A0h)

0~95
Serial ID Defined by SFP MSA (96 bytes)
96~127
Vendor Speific (32 bytes)
128~255
Reserved (128 bytes)

6.2 DDM THRESHOLD

	Low Alarm	Low Warn	High Warn	High Alarm
Temperature	-6°C	0°C	70°C	75°C
Voltage	3V	3.1V	3.5V	3.6V
Tx Bias	15mA	20mA	90mA	100mA
Tx Power	-3dBm	-2dBm	5dBm	7dBm
Rx Power	-27dBm	-26dBm	-8dBm	-7dBm

7. Mechanical Specifications

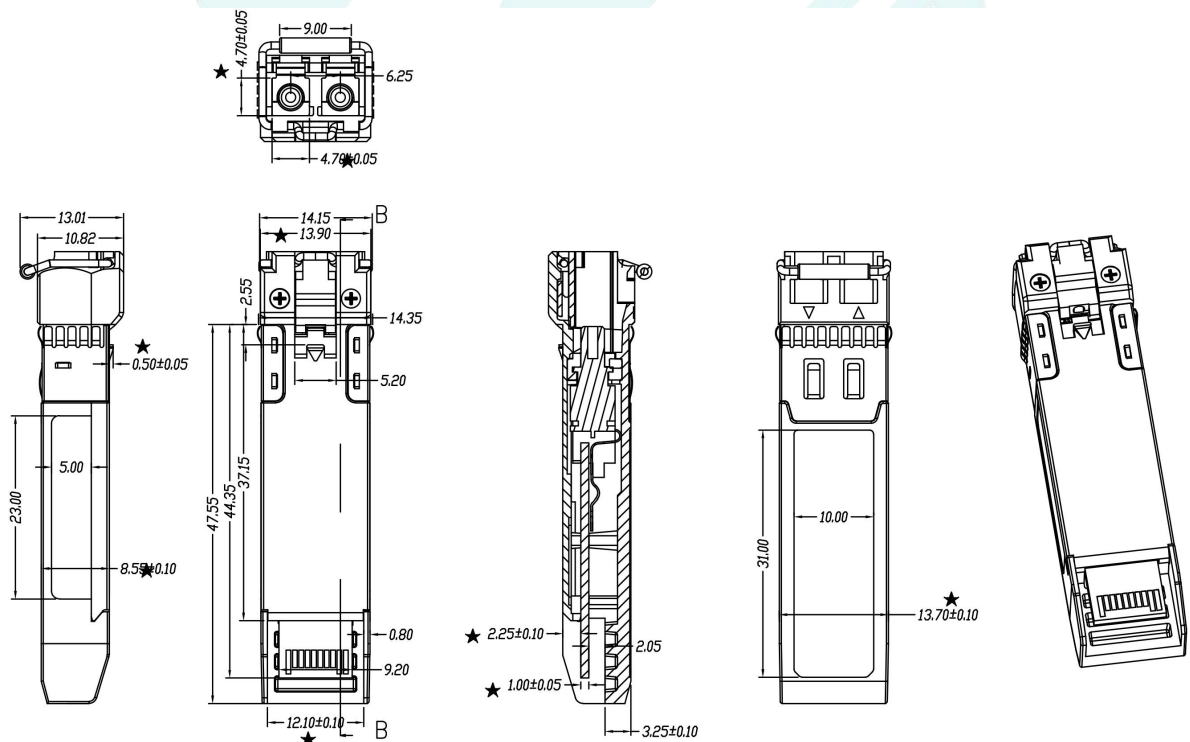

8. LABEL

C-LIGHT offers label OEM design and print.
Label barcode supports code128 and 2D barcode
SIZE: 26mm*10.5mm

C-LIGHT



Ordering Information

Part No.	Data Rate	DDM	Wave	Fiber Type	Dist.	Temp.	Optical Interface
CLSFPP1510GZR	10Gbps	yes	1550nm	SMF	80km	0~70℃	LC

*** WARNING: PLEASE KEEP THE RECEIVED POWER LOWER THAN -7dBm**

VERSION UPDATE:

VERSION NO.	DATE	UPDATED INFORMATION
V20160818	20160818	1. EEPROM& DDM Threshold updated 2. "LABEL" added 3. Ordering information updated 4. Product picture updated

NOTICE:

C-LIGHT reserves the right to make changes to this product in this specification without notice, in order to improve product performance.

CONTACT:

Shenzhen C-Light network communication co., Ltd

4F East, Building 1, Shunheda Factory Plant, Liuxiandong industrial park,
Xili, Nanshan Dist, Shenzhen PR. China

Tel: 86-755-2778-9180 **Fax:** 86-755-2778-9174

E-mail: sales@c-light.com <http://www.c-light.com>